

WORKING IN A MULTI-STANDARDS METADATA ENVIRONMENT: FRBR, AACR2 & RDA, OCLC

Guest Lecture for LIS5703, Dr. Michelle Kazmer, FSU College of Communication and Information, March 6, 2014

MULTI-STANDARDS METADATA ENVIRONMENT

Objectives of this class:

To gain understanding of:

- ✗ FRBR as a entity relationship model

To gain understanding of the differences between:

- ✗ Content, Display, and Encoding Standards
- ✗ AACR2 and RDA

To become aware of OCLC policies that will create:

- ✗ AACR2-RDA hybrid records

MULTI-STANDARDS METADATA ENVIRONMENT

FRBR

Entity-Relationship Model

MULTI-STANDARDS METADATA ENVIRONMENT

Functional Requirements for Bibliographic Records *user* tasks:

- × Find
- × Identify
- × Select
- × Obtain

MULTI-STANDARDS METADATA ENVIRONMENT

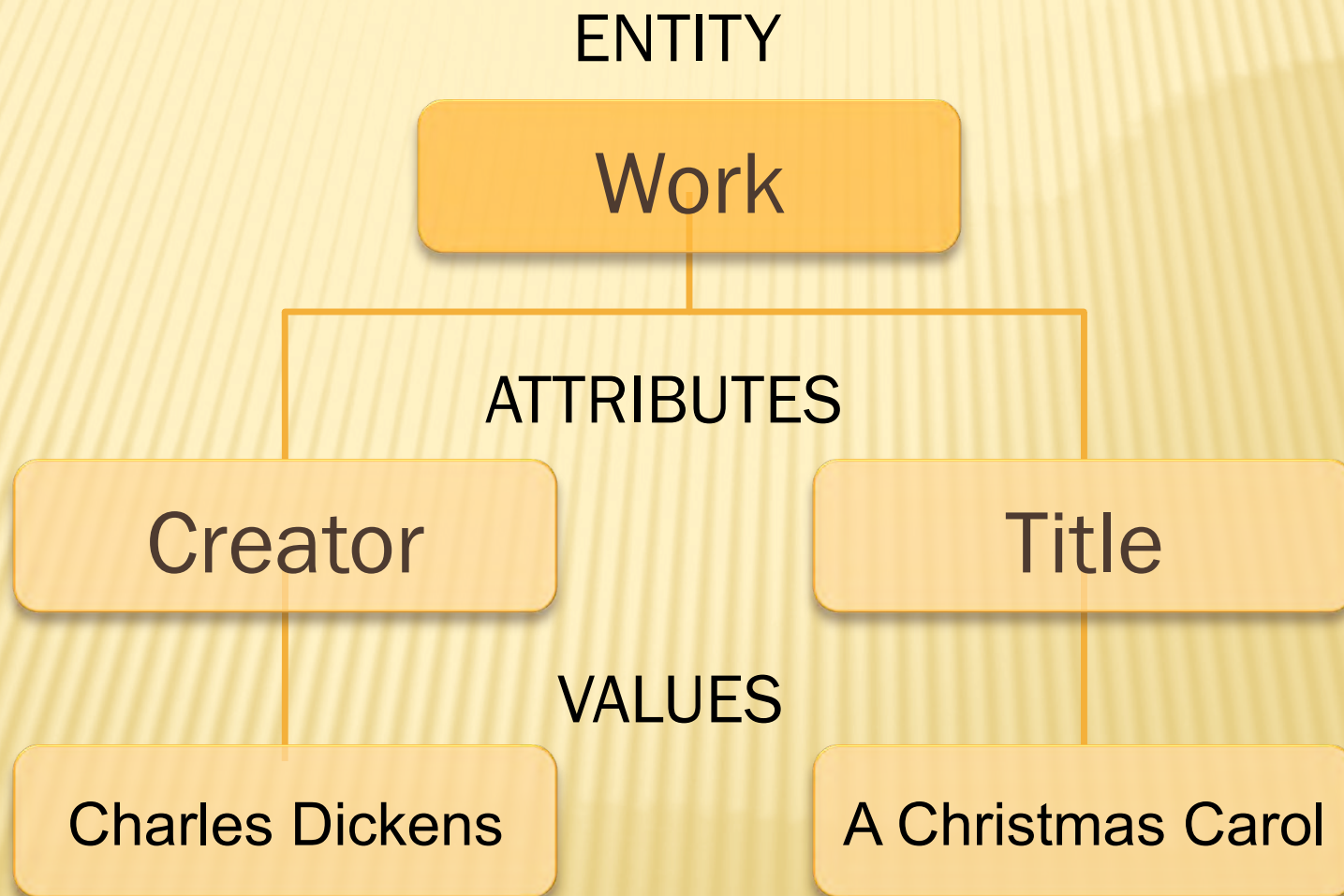

MULTI-STANDARDS METADATA ENVIRONMENT

Group One Entities

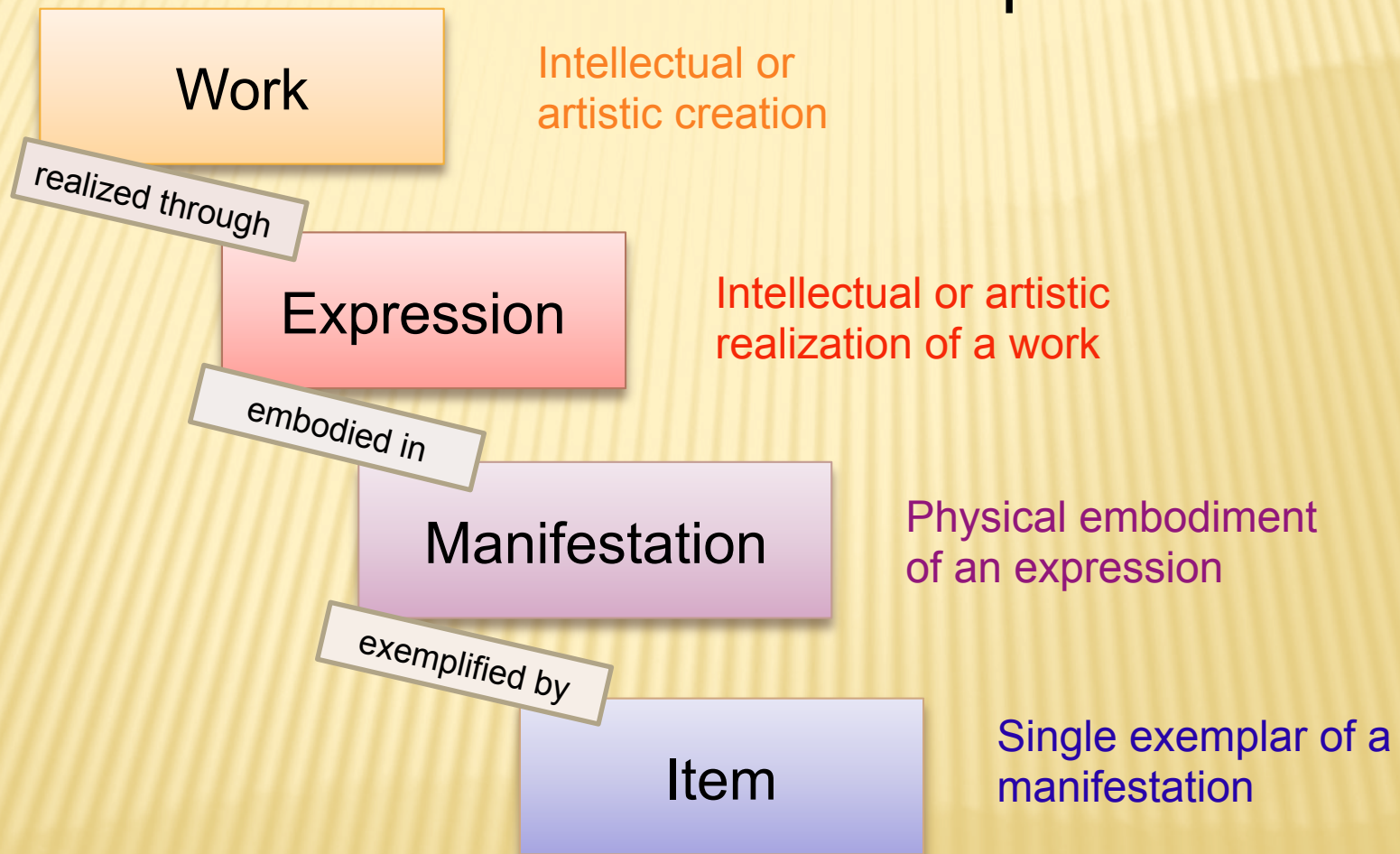

MULTI-STANDARDS METADATA ENVIRONMENT

Group Two Entities

Person

an individual

Family

A group of related
persons

Corporate
Body

an organization or group of
individuals and/or organizations

MULTI-STANDARDS METADATA ENVIRONMENT

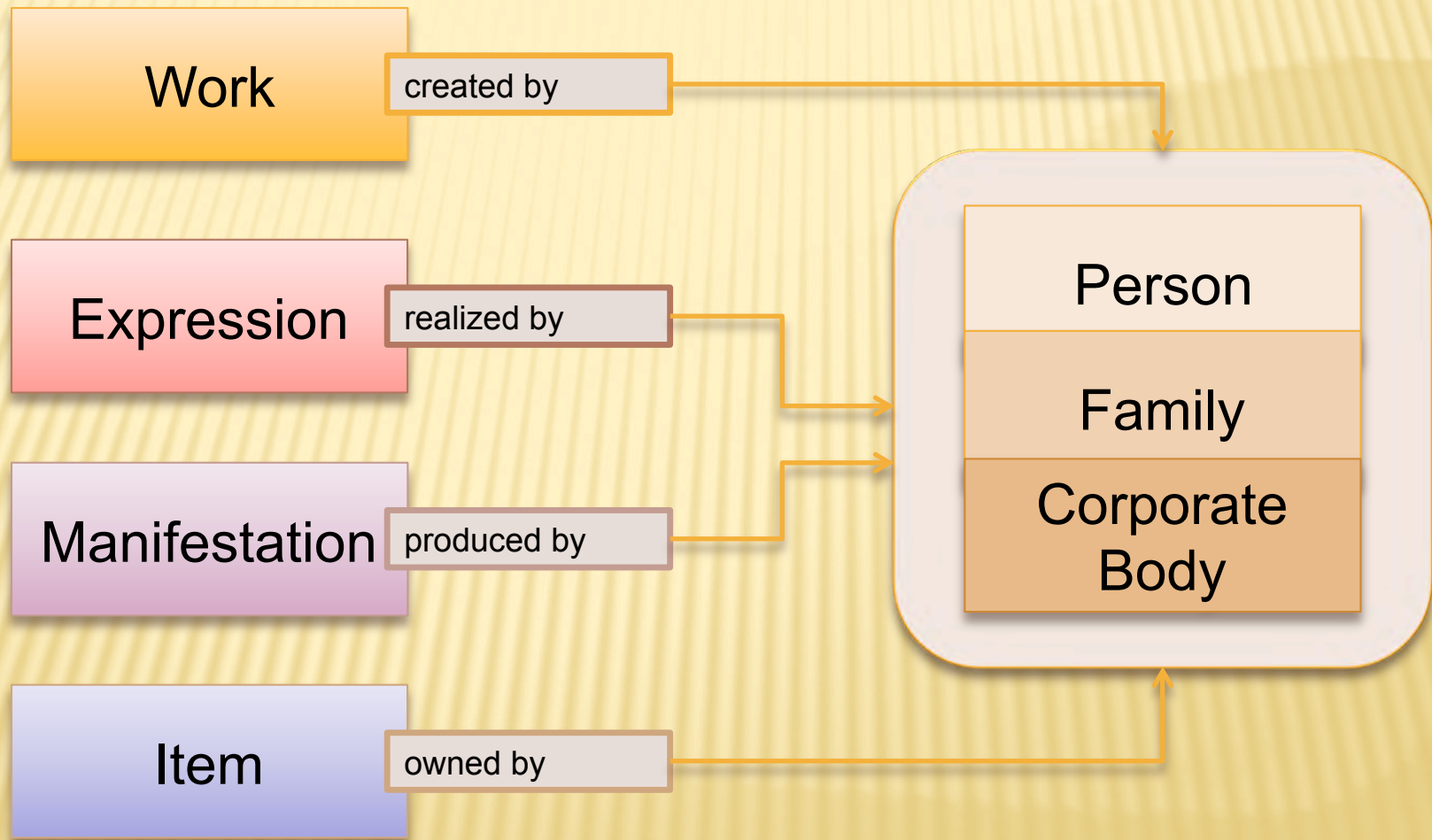

MULTI-STANDARDS METADATA ENVIRONMENT

Group Three Entities

Concept

an abstract notion
or idea

Object

a material thing

Event

an action or occurrence

Place

a location

MULTI-STANDARDS METADATA ENVIRONMENT

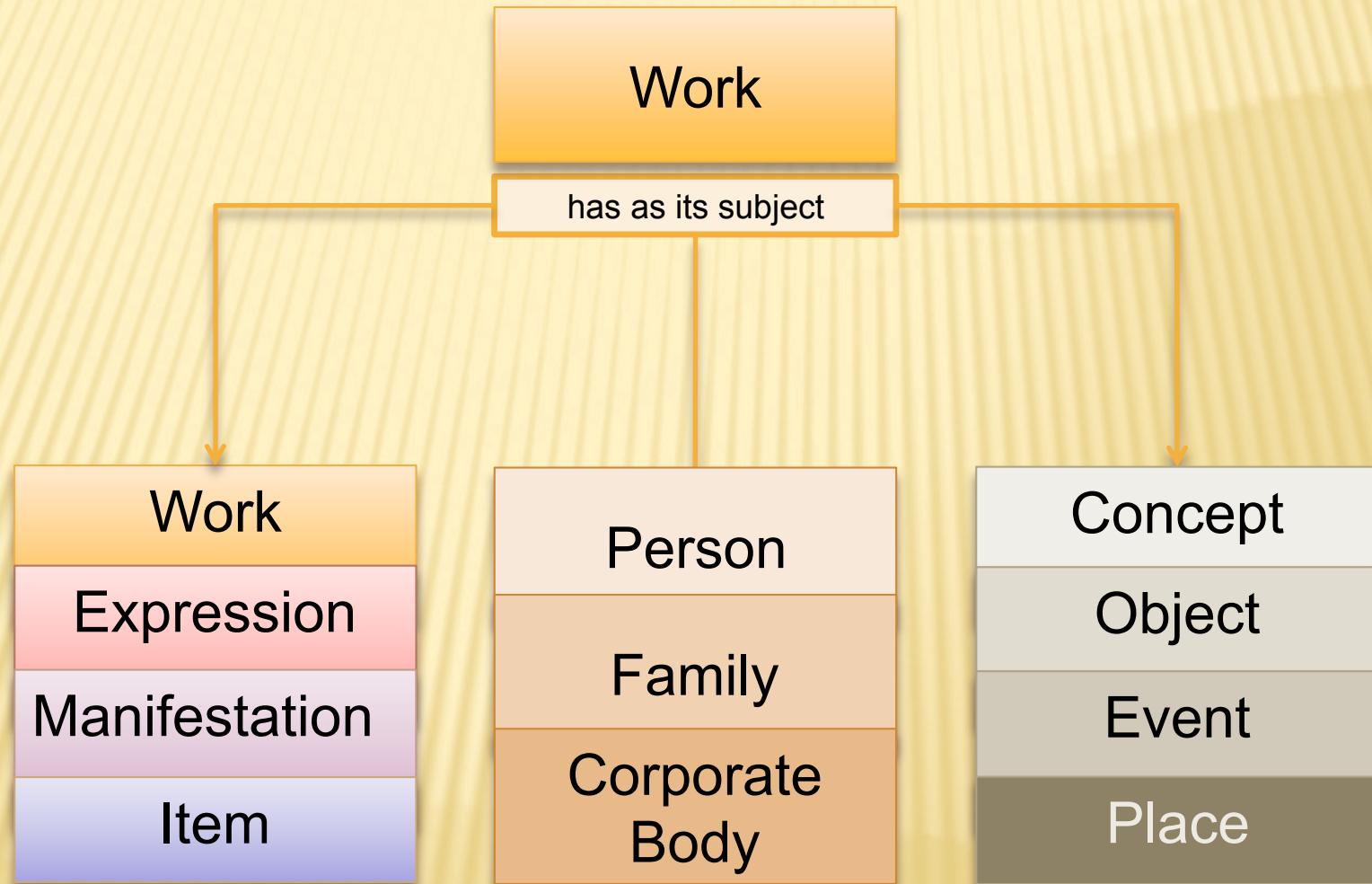

MULTI-STANDARDS METADATA ENVIRONMENT

Group 1 entities

Type a Form _ LitF d

Lang eng Ctry enk Date 1703

100 \$a Shakespeare, William, \$d
1564-1616.

240 \$a Hamlet.

245 \$a The tragedy of Hamlet, Prince of
Denmark : \$b as it is now acted by Her
Majesties servants / \$c by William
Shakespeare.

260 \$a London : \$b Printed for Rich.
Wellington ... and E. Rumball ..., \$c
1703.

300 \$a [4], 82 p. ; \$c 22 cm.

590 \$a Signatures: [A]² B-L⁴ M² (last leaf
wanting in LC copy).

650 \$a Hamlet (Legendary character)

655 \$a Tragedies. \$2 gsafd

100 \$a Shakespeare, William, \$d 1564-1616.

240 \$a Hamlet.

Type a LitF d Lang eng

245 \$a The tragedy of Hamlet, Prince of Denmark :
655 Tragedies. \$2 gsafd

Form _ Ctry enk Date 1703

245 \$a The tragedy of Hamlet, Prince of Denmark :
\$b as it is now acted by Her Majesties servants / \$c
by William Shakespeare.

260 \$a London : \$b Printed for Rich. Wellington ...
and E. Rumball ..., \$c 1703.

300\$a [4], 82 p. ; \$c 22 cm.

590 \$a Signatures: [A]² B-L⁴ M² (last leaf wanting in
LC copy).

Group 2 entities

100 \$a Shakespeare, William, \$d 1564-1616.

Group 3 entities

650 \$Hamlet (Legendary character).

MULTI-STANDARDS METADATA ENVIRONMENT

Content, Display, & Encoding Standards

MULTI-STANDARDS METADATA ENVIRONMENT

Content

Which bibliographic elements should be included in the description?



MULTI-STANDARDS METADATA ENVIRONMENT

Display

How should those bibliographic elements be *displayed*?

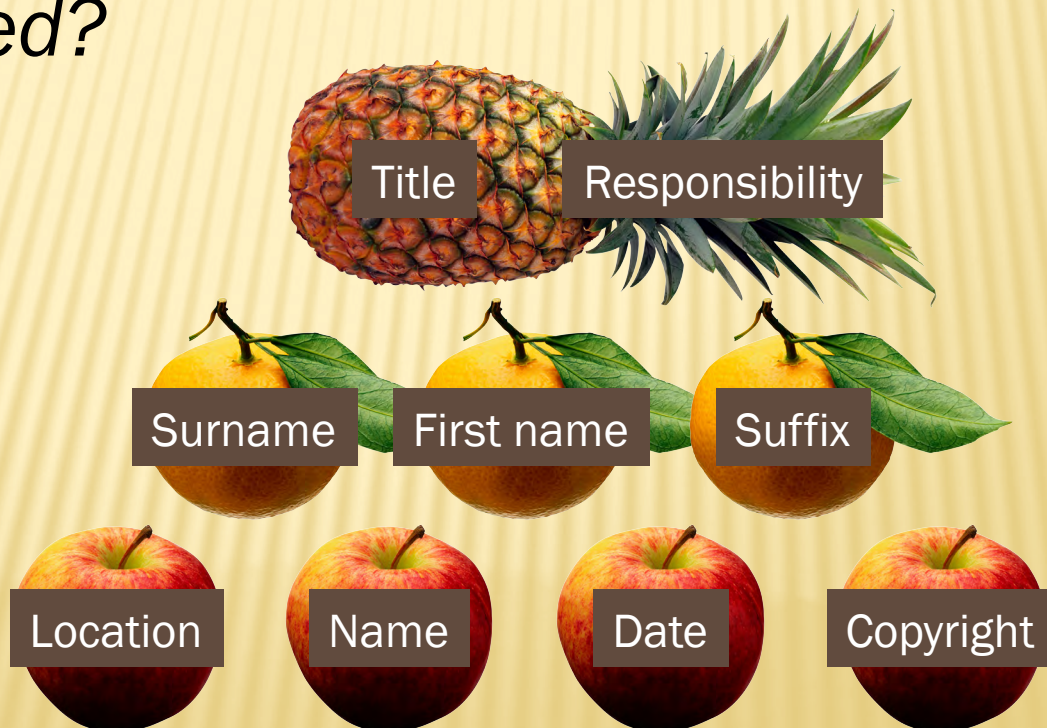

MULTI-STANDARDS METADATA ENVIRONMENT

Encoding

Which metadata schema should *contain* the descriptive data?



MULTI-STANDARDS METADATA ENVIRONMENT

Content

Which bibliographic elements should be included in the description?



MULTI-STANDARDS METADATA ENVIRONMENT

Display

How should those bibliographic elements be *displayed*?



**International Standard Bibliographic Description
(ISBD)**



MULTI-STANDARDS METADATA ENVIRONMENT

Encoding

Which metadata schema should *contain* the descriptive data?



MULTI-STANDARDS METADATA ENVIRONMENT

AACR2 and RDA

MULTI-STANDARDS METADATA ENVIRONMENT

AACR2



HEADING

[Uniform Title]

Title proper / Responsibility.

- Edition. - PubLocation :

PubName, Pub date. -- # p. :

ill. ; # cm - Notes - ISBN.

I. TITLE 1. Subject 2. Subject

MULTI-STANDARDS METADATA ENVIRONMENT

RDA

R | D | A

RESOURCE DESCRIPTION & ACCESS

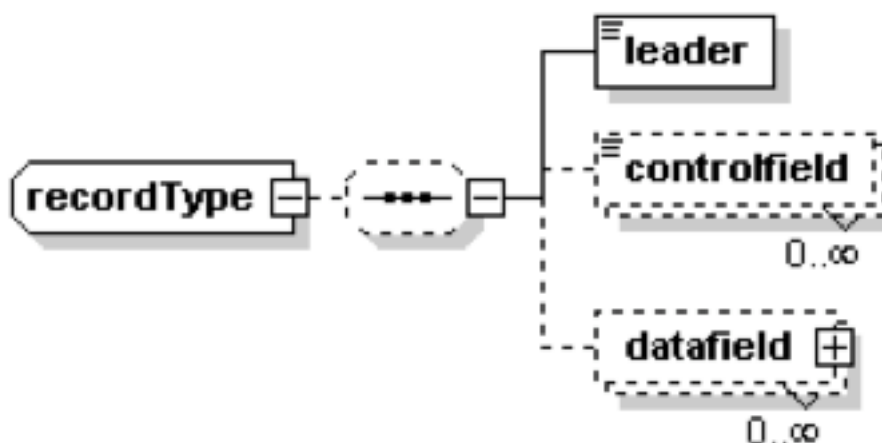

MULTI-STANDARDS METADATA ENVIRONMENT

AACR2 vs. RDA

How are AACR2 and RDA the same?

- ✘ Both establish a *standard* for bibliographic description so that information resources can be found, identified, selected, and accessed
- ✘ RDA built of the ‘bricks’ of AACR2
 - Dismantled, reconstructed, remodeled

MULTI-STANDARDS METADATA ENVIRONMENT

AACR2 vs. RDA

How is RDA different than AACR2?

- ✗ Based on FRBR, a conceptual entity-relationship model
- ✗ Designed for a digital environment: RDA Toolkit
- ✗ “Take what you see, accept what you get.”*
 - Less abbreviations and truncation, less stringent capitalization rules

* Dr. Barbara B. Tillett, Chief, Policy and Standards Division, Library of Congress

MULTI-STANDARDS METADATA ENVIRONMENT

AACR2 vs. RDA

- ✗ RDA is a *content* standard, but not a *display* standard like AACR2
- ✗ RDA is not an *encoding* standard, like MARC which was based on ISBD and AACR2
- ✗ RDA focuses on local *user* needs:
 - Agency preparing the description chooses the language, script, numeric system

MULTI-STANDARDS METADATA ENVIRONMENT

AACR2 vs. RDA

ACCESS—Name
ACCESS—Subject
ACCESS—Subject
ACCESS—Title

WORK—Name
WORK—Title

EXPRESSION—Edition

HEADING

[Uniform Title]

Title proper / Responsibility.

– Edition. – PubLocation :

PubName, Pub date. -- # p. :

ill. ; # cm – Notes – ISBN.

1. Subject 2. Subject I. TITLE

MANIFESTATION—Title proper
MANIFESTATION—Responsibility
MANIFESTATION—Edition
MANIFESTATION—PubLocation
MANIFESTATION—PubName
MANIFESTATION—PubDate
MANIFESTATION—Extent
MANIFESTATION—Physical details
MANIFESTATION—Dimensions
MANIFESTATION—Notes
MANIFESTATION—ISBN

MULTI-STANDARDS METADATA ENVIRONMENT

AACR2 Part 1 is based on ISBD Areas of Description

1. Title and statement of responsibility
2. Edition area
3. Material specific details
4. Publication, etc.
5. Physical description
6. Series
7. Notes
8. Standard numbers and terms of availability

Part 2 covers access points

RDA is based FRBR entities

Group 1 Entities:

Work, Expression,
Manifestation, Item

Group 2 Entities:

Persons, Corporate Bodies,
Families

Group 3 Entities:

Concept, Object, Event, Place

MULTI-STANDARDS METADATA ENVIRONMENT

Author: Dickens, Charles,
1812-1870.

Uniform title: Christmas carol

Title: A Christmas carol : in
prose ; being a ghost story
of Christmas

Publisher: London : Chapman
& Hall, 1843.

Physical description: 166 p.,
[4] leaves of plates : ill.
(some col.) ; 17 cm.

Language: English

Entity: Person; **Role:** Creator; **Value:**
Dickens, Charles, 1812-1870

Entity: Work; **Element:** Preferred title;
Value: Christmas carol

Entity: Work; **Element:** Title; **Value:** A
Christmas carol : in prose ; being a
ghost story of Christmas

Entity: Expression; **Element:** Language;
Value: English

Entity: Manifestation; **Element:**
Publisher name; **Value:** Chapman &
Hall

Entity: Manifestation; **Element:** Extent;
Value: 166 pages, 4 unnumbered
leaves of plates

MULTI-STANDARDS METADATA ENVIRONMENT

AACR2 vs. RDA

Terminology

Heading	=	Authorized Access Point
Author, Composer, etc.	=	Creator
Main Entry	=	Preferred title; Creator's Authorized Access Point
Uniform Title	=	Preferred Title & Qualifiers or Generic Collective Title

MULTI-STANDARDS METADATA ENVIRONMENT

AACR2 vs. RDA

Terminology

See reference	=	Variant access point
See also reference	=	Authorized access point for related entity
Physical description	=	Carrier description
Chief source	=	Preferred sources
GMD	=	Content type + Media type + Carrier type

MULTI-STANDARDS METADATA ENVIRONMENT

AACR2 Record in Mango

Title: The Nature and **future** of the **catalog** : proceedings of the ALA's Information Science and Automation Division's 1975 and 1977 institutes on the **catalog**
edited by Maurice J. Freedman and S. Michael Malinconico.

Published: Phoenix, AZ : Oryx Press, 1979.

Description: xvi, 317 p. : ill. ; 24 cm.

Notes: "A Neal-Schuman professional book."
Includes bibliographical references and index.

ISBN: 0912700084 :

Subjects, general: **Cataloging** -- Congresses
Libraries -- Automation -- Congresses
Library **catalogs** -- Congresses

Subjects, medical: **Cataloging** -- congresses
Catalogs, Library -- congresses

Other author(s), etc: American Library Association Information Science and Automation Division
Freedman, Maurice J.
Malinconico, S. Michael

Format: Book

The Nature
and Future of
The Catalog
Division

more info @
Google™

MULTI-STANDARDS METADATA ENVIRONMENT

RDA Record in Mango

Title: **Conversations with catalogers in the 21st century**
Elaine R. Sanchez, editor ; foreword by Michael Gorman.

Published: Santa Barbara, California : Libraries Unlimited, [2011], ©2011.

Description: xii, 283 pages : illustrations ; 24 cm.

Series note: Libraries Unlimited library management collection

Series: Libraries Unlimited library management collection.

Alternate title: **Conversations with catalogers in the twenty-first century**

Notes: Includes bibliographical references and index.

Summary: "Authored by **cataloging** librarians, educators, and information system experts, this book of essays addresses ideas and methods for tackling the modern challenges of **cataloging** and metadata practices"-- Provided by publisher.

ISBN: 1598847023 (pbk. : acid-free paper)
9781598847024 (pbk. : acid-free paper)

Subjects, general: **Cataloging -- History -- 21st century**

Other author(s), etc: Sanchez, Elaine

Format: Book



MULTI-STANDARDS METADATA ENVIRONMENT

1. Title and Statement of responsibility	Personal names	Corporate names	Meeting names	
2. Edition statement				
3. Material specific designation				
4. Publication, etc.	Series titles	Uniform titles		
5. Physical description				
6. Series statement				
7. Notes	Topical	Geographic	Names	Titles
8. Numbers and terms of availability				

MULTI-STANDARDS METADATA ENVIRONMENT

245 \$a [Title] / \$c [Statement of responsibility]	100 [Name] 700 [Name]	110 [Corporate name] 710 [Corporate name]	111 [Meeting name] 711 [Meeting name]
250 \$a [Edition statement]			
245 \$h [Material specific designation]			
260 \$a [Publication place] : \$b [Publisher name], \$c [Publication date].	800 [Name/Series title] 810 [Corp. Name/ Series title] 830 [Series title]	130 [Uniform title] 730 [Uniform title]	
300 \$a [Extent] : \$b [Illustrative matter] ; \$c [Dimensions].			
490 \$a [Series statement]			
5xx \$a [Notes]. 546 \$a [Language note]. 504 \$a [Bibliography note]. 505 \$a [Contents note].	650 [Topical]	651 [Geographic]	600 [Name]
0xx \$a [Numbers and coded data] 020 \$a [ISBN]			630 [Title]

MULTI-STANDARDS METADATA ENVIRONMENT

Call number: Z693.A15 N39
Publication: Phoenix, AZ : Oryx Press,
1979.
Description: xvi, 317 p. : ill. ; 24 cm.
Notes: Includes bibliographical
references and index.
Subject: Cataloging--Congresses.
Subject: Library catalogs--
Congresses.
Added name: Freedman, Maurice J.

Author, etc.: [Daly, Richard R.](#)
Title: [The future crisis in the card catalog : how libraries are preparing for it / by Richard R. Daly](#)
Published: Media, PA : Information Associates, c1979.
Description: 12 p. ; 22 cm.
Subjects, general: [Card catalogs.](#)
Format: BK
Material type: <Book>

MULTI-STANDARDS METADATA ENVIRONMENT

Books Digital Collections Course Reserves

Basic Search Search begins with (browse) Advanced Search

Conversations with catalogers in the 21st Anywhere Search Start Over

Search: 'Conversations with catalogers in the 21st century' :
We found **6** matching items at FSU [Show 25 items that you can request statewide](#)  (what's this?)
[Did you mean conversations with catalog in the 21st century?](#)

Narrow Results By:

Books in the library

Library/Collection

- STROZIER LIBRARY (5)
- GOLDSTEIN LIBRARY (1)

[show more...](#)

Series Title

- Libraries Unlimited library management collection (1)

Subject: Topic



- Art, Modern (2)
- History (2)
- Art, American (1)









[show more...](#)

Author

- Ahuja, Sunil (1)
- Balkema, Annette W. (1)
- Blauvelt, Andrew 1964- (1)

[show more...](#)

 My Folder is empty [Add All](#) **Results/page:** 10 **Sort By:** Relevance 

- 1. Conversations with catalogers in the 21st century**
Elaine R. Sanchez, editor ; foreword by Michael Gorman.
Published: Santa Barbara, California : Libraries Unlimited, [2011], ©2011.
Summary: "Authored by cataloging librarians, educators, and information system experts, this book of essays addresses ideas and methods for tackling the modern challenges of cataloging and metadata practices"--
 book
GOLDSTEIN LIBRARY Professional 2693 .C65 2011 **Due 1/4/12 10 PM**
[Place a Hold](#)
 add  print  email  txt  cite this  export
- 2. Unser Jahrhundert : ein Gespräch**
Helmut Schmidt, Fritz Stern.
Author: Schmidt, Helmut 1918 Dec. 23-
Published: München : C.H. Beck, c2010.
Summary: ""Get Started, Fritz"- this sentence begins a conversation with friends...[see more](#)
 book

MULTI-STANDARDS METADATA ENVIRONMENT

Boxed Data

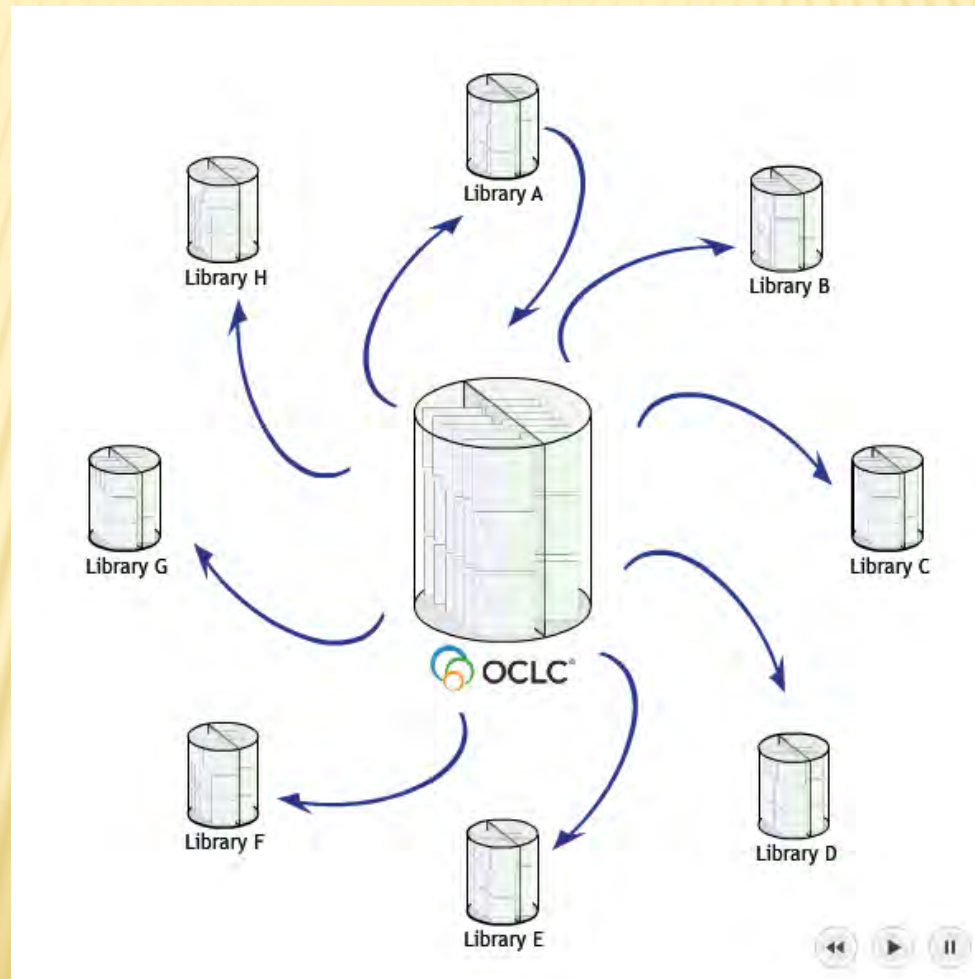

MULTI-STANDARDS METADATA ENVIRONMENT

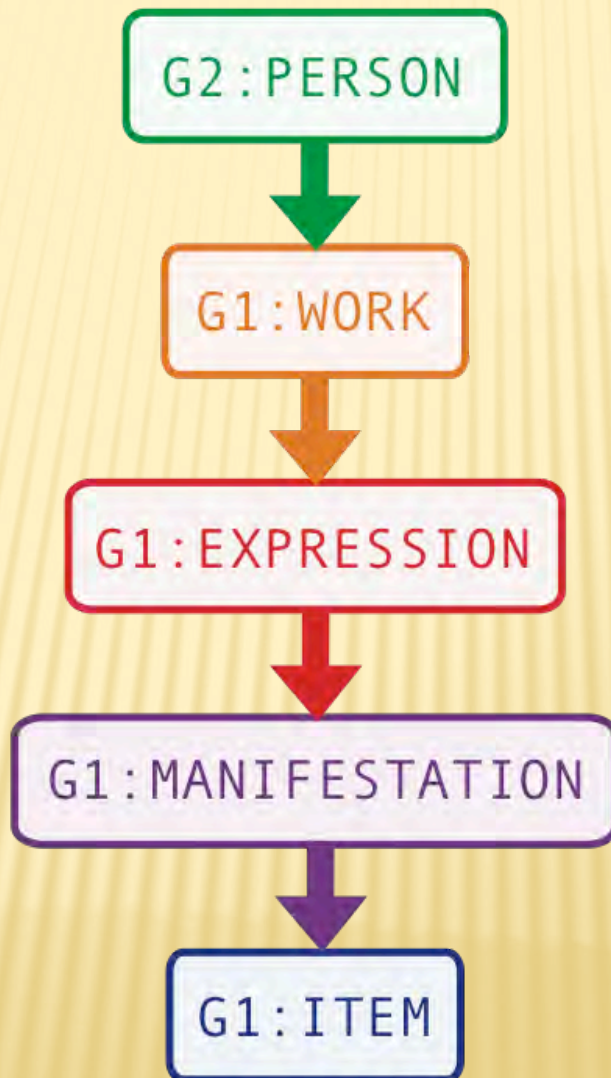

MULTI-STANDARDS METADATA ENVIRONMENT

```
<frbr:Person>
  <rdaElement:idPerson> uri= "[VALUE]" />
  <rdaElement:PreferredName>[VALUE]
</rdaElement:PreferredName>
  <rdaElement:AssociatedDate>
    <rdaSubelement:birthdate>[VALUE]
    </rdaSubelement:birthdate>
  </rdaElement:AssociatedDate>
</frbr:Person>
```

```
<frbr:Work>
  <rdaElement:idWork> uri= "[VALUE]" />
  <rdaElement:PreferredTitle>[VALUE]
</rdaElement:PreferredTitle>
  <rdaElement:WorkCreator>
    <role:author>
      <rdaElement:idPerson> uri= "[VALUE]" />
    </role:author>
  </rdaElement:WorkCreator>
</frbr:Work>
```

```
<frbr:Expression>
  <rdaElement:idExpression> uri= "[VALUE]" />
  <link:idWork> uri= "[VALUE]" />
  <rdaElement:Language>[VALUE]
</rdaElement:Language>
</frbr:Expression>
```

```
<frbr:Manifestation>
  <rdaElement:idManifestation> uri= "[VALUE]" />
  <link:idExpression> uri= "[VALUE]" />
  <rdaElement:TitleProper>[VALUE]
</rdaElement:TitleProper>
  <rdaElement:PublicationDate>[VALUE]
</rdaElement:PublicationDate>
  <rdaElement:Extent>[VALUE]
</rdaElement:Extent>
  <rdaElement:CarrierType>[VALUE]
</rdaElement:CarrierType>
</frbr:Manifestation>
```

```
<frbr:Item>
  <rdaElement:idItem> uri= "[VALUE]" />
  <link:idManifestation> uri= "[VALUE]" />
  <rdaElement:Location>[VALUE]
</rdaElement:Location>
  <rdaElement:Classification>[VALUE]
</rdaElement:Classification>
</frbr:Item>
```

MULTI-STANDARDS METADATA ENVIRONMENT

```
<frbr:Person>
  <rdaElement:idPerson uri= "[VALUE]" />
  <rdaElement:PreferredName>[VALUE]
</rdaElement:PreferredName>
  <rdaElement:AssociatedDate>
    <rdaSubelement=birthdate>[VALUE]
    </rdaSubelement=birthdate>
  </rdaElement:AssociatedDate>
</frbr:Person>
```

```
<frbr:Work>
  <rdaElement:idWork uri= "[VALUE]" />
  <rdaElement:PreferredTitle>[VALUE]
</rdaElement:PreferredTitle>
  <rdaElement:WorkCreator>
    <role:author>
      <rdaElement:idPerson uri= "[VALUE]" />
    </role:author>
  </rdaElement:WorkCreator>
</frbr:Work>
```

MULTI-STANDARDS METADATA ENVIRONMENT

Linked Data

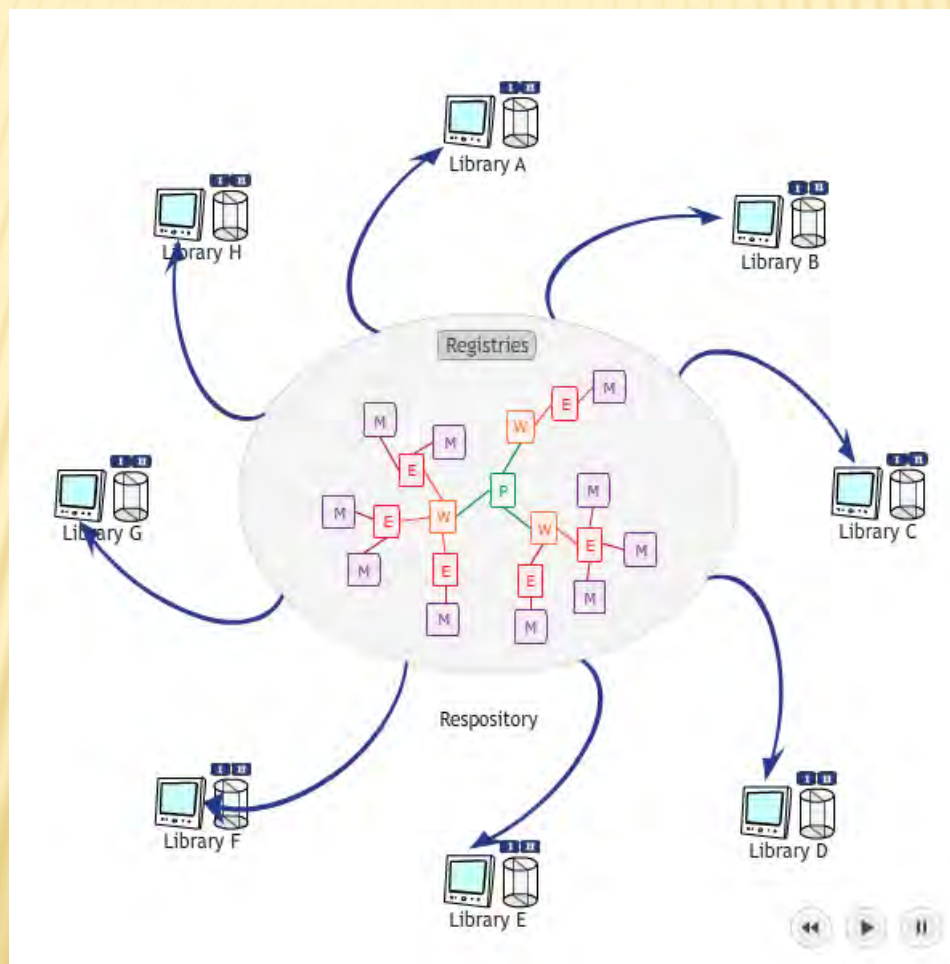

MULTI-STANDARDS METADATA ENVIRONMENT

BIBFRAME.ORG New Bibliographic Framework

Overview Vocabulary Demos Tools Contribute

Home

BIBFRAME Model Overview



The [Library of Congress](#) has launched the [Bibliographic Framework Transition Initiative](#) to better accommodate future needs of the library community. A major focus of the initiative will be to determine a transition path for the MARC 21 exchange format to more Web based, Linked Data standards. [Zepheira](#) and The Library of Congress are working together to develop a Linked Data model, vocabulary and enabling tools / services for supporting this Initiative.

[BIBFRAME.ORG](#) provides an overview of this effort. This site offers:

- A [demonstration area](#) where the model is being tested and displayed using different test suites of data
- View of the BIBFRAME [vocabulary](#) along with supporting formal specifications
- Educational resource on how the BIBFRAME vocabulary relates to MARC21 fields and subfields
- [Code](#) and [supporting services](#).

Additional background on this initiative can be found here:

- [LC's Bibliographic Framework Initiative: An Update](#) (November 29, 2012)
- [Bibliographic Framework as a Web of Data: Linked Data Model and Supporting Services](#) (November 21, 2012)
- [Bibliographic Framework Initiative Approach for MARC Data as Linked Data](#) (September 2012)
- [Webcast of New Bibliographic Framework: Update with Eric Miller](#) (July 16, 2012)
- [The Library of Congress Announces Modeling Initiative](#) (May 22, 2012)
- [Transforming our Bibliographic Framework: A Statement from the Library of Congress](#) (May 13, 2011)
- [A Bibliographic Framework for the Digital Age](#) (October 31, 2011)

BIBFRAME.ORG is a collaborative effort of [US Library of Congress](#), [Zepheira](#) and you!

BIBFRAME@LISTSERV.LOC.GOV

MULTI-STANDARDS METADATA ENVIRONMENT

BIBFRAME.ORG New Bibliographic Framework

Overview Vocabulary Demos Tools Contribute

Home Vocab

The BIBFRAME Model

In translating the MARC 21 format to a Linked Data model it is important to deconstruct and then reconstruct the informational assets that comprise MARC. The BIBFRAME Model consists of the following core classes:

- **Creative Work** - a resource reflecting a conceptual essence of the cataloging resource.
- **Instance** - a resource reflecting an individual, material embodiment of the Work.
- **Authority** - a resource reflecting key authority concepts that have defined relationships reflected in the Work and Instance. Example of Authority Resources include [People](#), [Places](#), [Topics](#), [Organizations](#), etc. One important concept in Authority is domain, which is the entity taking responsibility for the recognition, organization and maintenance (to ensure integrity) of the authoritative resources.
- **Annotation** - a resource that decorates other BIBFRAME resources with additional information such as [Library Holdings](#), [Cover Art](#) and [Reviews](#)

These Information Resources can then be re-assembled into a coherent architecture that allows for cooperative cataloging at a far more granular level than before. Then, as we leverage the Web as an architecture for data, whenever updates to these Resources are performed (e.g. someone adds new information about a Person, new mappings related to a Subject, etc.) notification events can occur to automatically update systems that reference these Resources. Further, these information assets can now be more effectively utilized at a granular level and provide a richer substrate in which local collections, special collections and third party data can easily annotate and contextualize cooperative library content.

```
graph TD; Work((Work)) -- subject --> Subject((Subject)); Work -- creator --> Creator((Creator)); Work -- hasInstance --> Instance((Instance)); Instance -- publisher --> Publisher((Publisher)); Instance -- publishedAt --> PublishedAt((PublishedAt)); Instance -- format --> Format((Format));
```

BIBFRAME.ORG is a collaborative effort of [US Library of Congress](#), [Zepheira](#) and you!

MULTI-STANDARDS METADATA ENVIRONMENT

OCLC Hybrid Records

MULTI-STANDARDS METADATA ENVIRONMENT

OCLC Policy as of March 31, 2013

Original Cataloging

- ✗ Records may be entered in RDA, AACR2, or any other recognized cataloging code
- ✗ Use name access points from the LC/NACO authority file
 - Okay if the description follows AACR2 rules but the names follow RDA instructions

MULTI-STANDARDS METADATA ENVIRONMENT

OCLC Policy as of March 31, 2013

Copy Cataloging

- ✗ Not required to upgrade AACR2 records to RDA
- ✗ Do not change RDA master records to AACR2

Upgrading/Enhancing Existing Records

- ✗ Optional to upgrade minimal *and* full records to RDA, but only with the “piece in hand”
- ✗ Okay to enrich the record without upgrading to RDA

MULTI-STANDARDS METADATA ENVIRONMENT

OCLC Policy as of March 31, 2013

Hybrid Records

Okay to add RDA elements to non-RDA records:

- ✗ Relationship designators to access points
- ✗ Complete statements of responsibility in place of the first author only and "[et al.]"
- ✗ 336/337/338 fields
- ✗ Spelling out abbreviations (non-transcribed only)

MULTI-STANDARDS METADATA ENVIRONMENT

OCLC Policy as of March 31, 2013

Hybrid Records

OCLC will be globally changing AACR2 records

- ✗ Adding relationship designators
- ✗ Adding 336/337/338 fields
- ✗ Spelling out abbreviations (non-transcribed only) in 255, 300, 500, 504, and other fields
- ✗ Converting Latin abbreviations (*n.l.*, *s.n.*, *s.d.*) to English in 245, 260, and other fields

MULTI-STANDARDS METADATA ENVIRONMENT

OCLC Policy as of March 31, 2013

Hybrid Records

Access points (i.e. Headings) will be changed to RDA practices

- ✘ Abbreviations such as “Dept.” will be spelled out
- ✘ Dates, use “approximately” instead of “ca.”
- ✘ Headings for the Bible and the Koran will conform to RDA instructions

MULTI-STANDARDS METADATA ENVIRONMENT

AACR2

Desc a

040 __ KNM \$c KNM \$d OCLCQ

245 00 Oriental ceramics, the world's great collections / \$c British Museum ... [et al.].

250 __ Standard ed.

260 __ New York : \$b Kodansha International, \$c [ca. 1980-1982]

300 __ 11 v. : \$b ill. (some col.) ; \$c 37 cm.

710 2_ British Museum. \$b Dept. of Ceramics.

AACR2 Hybrid

Desc a

040 __ KNM \$c KNM \$d OCLCQ

245 00 Oriental ceramics, the world's great collections / \$c British Museum [and others].

250 __ Standard ed.

260 __ New York : \$b Kodansha International, \$c [approximately 1980-1982]

300 __ 11 volumes : \$b illustrations (some color) ; \$c 37 cm.

336 __ text \$2 rdacontent

337 __ unmediated\$2 rdamedia

338 __ volumes \$2 rdacarrier

710 2_ British Museum. \$b Department of Ceramics, \$e host institution.

*Disclaimer: These records are fictitious examples

MULTI-STANDARDS METADATA ENVIRONMENT

AACR2 Hybrid

Desc a

- 040 __ KNM \$c KNM \$d OCLCQ
- 245 00 Oriental ceramics, the world's great collections / \$c British Museum [and others].
- 250 __ Standard ed.
- 260 __ New York : \$b Kodansha International, \$c [approximately 1980-1982]
- 300 __ 11 volumes : \$b illustrations (some color) ; \$c 37 cm.
- 336 __ text \$2 rdacontent
- 337 __ unmediated\$2 rdamedia
- 338 __ volumes \$2 rdacarrier
- 710 2_ British Museum. \$b Department of Ceramics, \$e host institution.

*Disclaimer: These records are fictitious examples

RDA

Desc i

- 040 __ FDA \$b eng \$e rda \$d FDA
- 245 00 Oriental ceramics, the world's great collections / \$c British Museum, Freer Gallery of Art, National Museum of Korea, and Boston Museum of Fine Arts.
- 250 __ Revised edition.
- 264 _1 New York : \$b Kodansha International, \$c 2004.
- 300 __ 11 volumes : \$b illustrations (some color) ; \$c 40 cm
- 336 __ text \$2 rdacontent
- 337 __ unmediated\$2 rdamedia
- 338 __ volumes \$2 rdacarrier
- 710 2_ British Museum. \$b Department of Ceramics, \$e host institution.

MULTI-STANDARDS METADATA ENVIRONMENT

Any questions?

Please don't hesitate to contact me!

Annie Glerum

Head of Complex Cataloging

FSU Libraries

aglerum@fsu.edu